

You must complete this before retaking the MC again. Remember it is all about LEARNING so take your time and learn how to do these skills. If you need help please ask!

NAME: _____

Corrective Assignment 13.1

Directions: Plot each given point. Make sure you show how you got to your point.

1) $(2, -4, 1)$

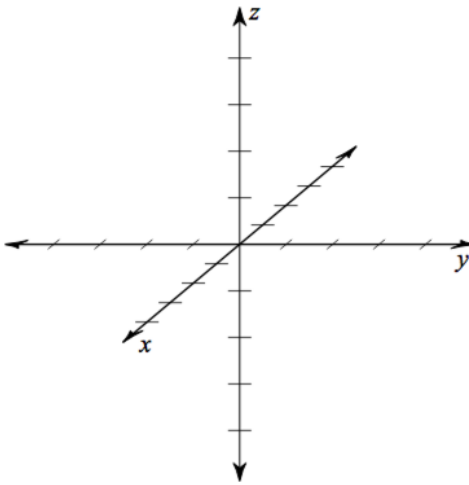

2) $(-3, -2, 1)$

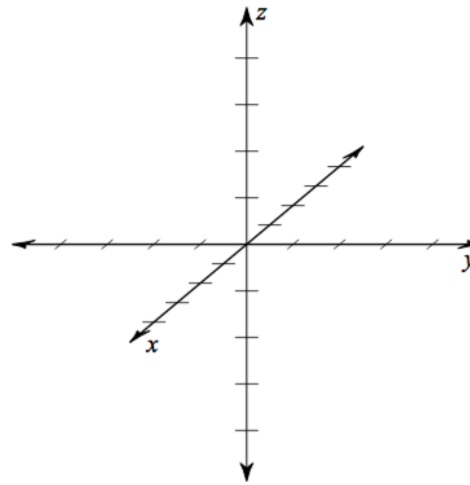

3) $(3, 3, -4)$

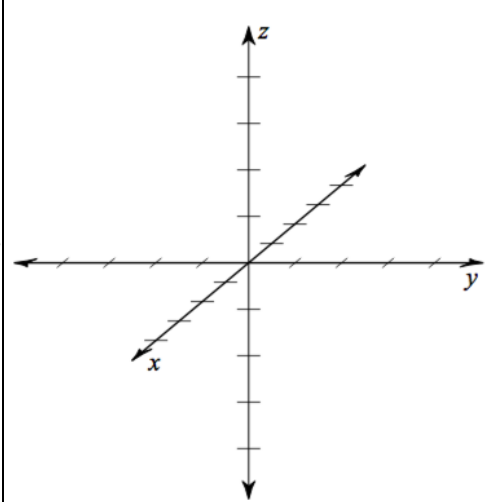

Directions: Find the distance and midpoint for each.

4) $(6, 10, 2)$ and $(-4, 5, -3)$

5) $(-5, 2, 5)$ and $(-6, 3, -6)$

6) $(-2, -2, -2)$ and $(13, 2, 0)$

7) $(3, 5, 3)$ and $(-5, -5, -7)$

Directions: Find the intercepts and graph the equation.

8) $x - 2y + z = 4$

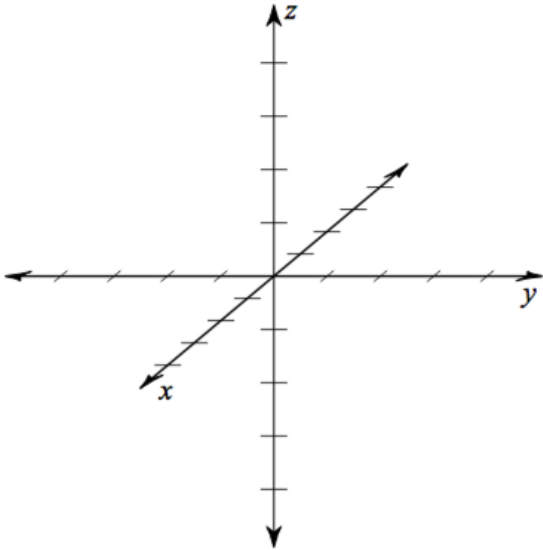

9) $2x + 3y - 6z = -6$

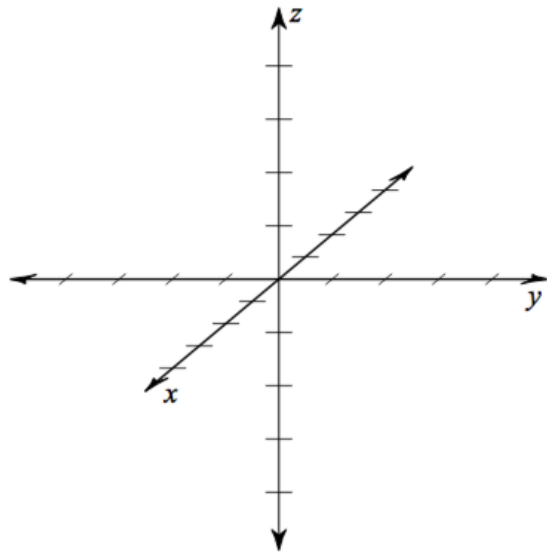

ANSWERS TO CORRECTIVE ASSIGNMENT:

Make sure you check all your answers and make sure you KNOW how to do all of them. You could simply copy answers but that's not the point. The point is that you have to learn how to do this so please make sure that for any you don't understand you get help BEFORE taking the Mastery Check again.

1) (2, -4, 1)

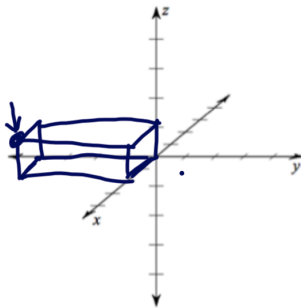

2) (-3, -2, 1)

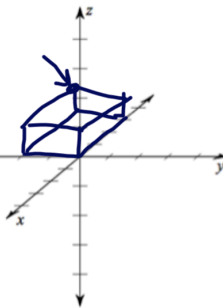

3) (3, 3, 4)

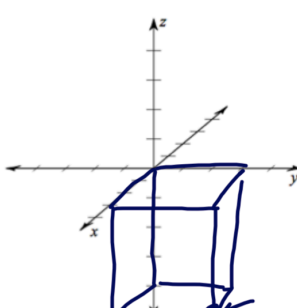

4) $d = 12.2, M = (1, 7.5, -0.5)$

5) $d = 11.1, M = (-5.5, 2.5, -0.5)$

6) $d = 15.7, M = (5.5, 0, -1)$

8) $d = 16.2, M = (-1, 0, -2)$

8) $x - 2y + z = 4$

$$x=4 \left\{ \begin{array}{l} -2y=4 \\ y=-2 \end{array} \right. \left\{ \begin{array}{l} z=4 \end{array} \right.$$

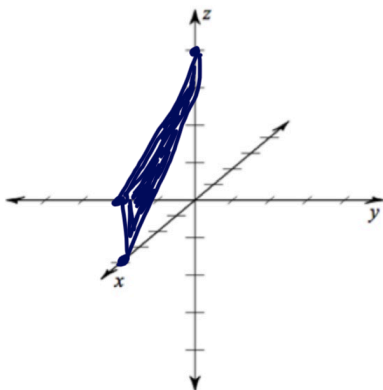

9) $2x + 3y - 6z = -6$

$$2x=-6 \left\{ \begin{array}{l} 3y=-6 \\ y=-2 \end{array} \right. \left\{ \begin{array}{l} -6z=-6 \\ z=1 \end{array} \right.$$

